

2005/03/14 (17:08:07)
 This drawing is provisional and subject to our reconfirmation and/or revision without notice.
 T1 SUPERSEB

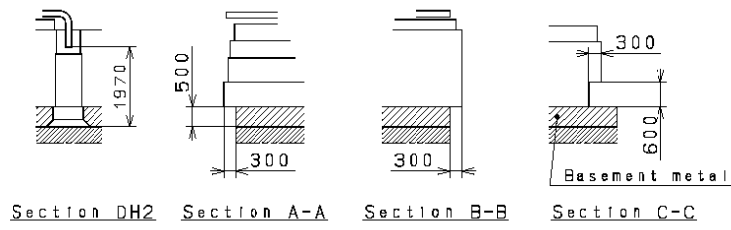
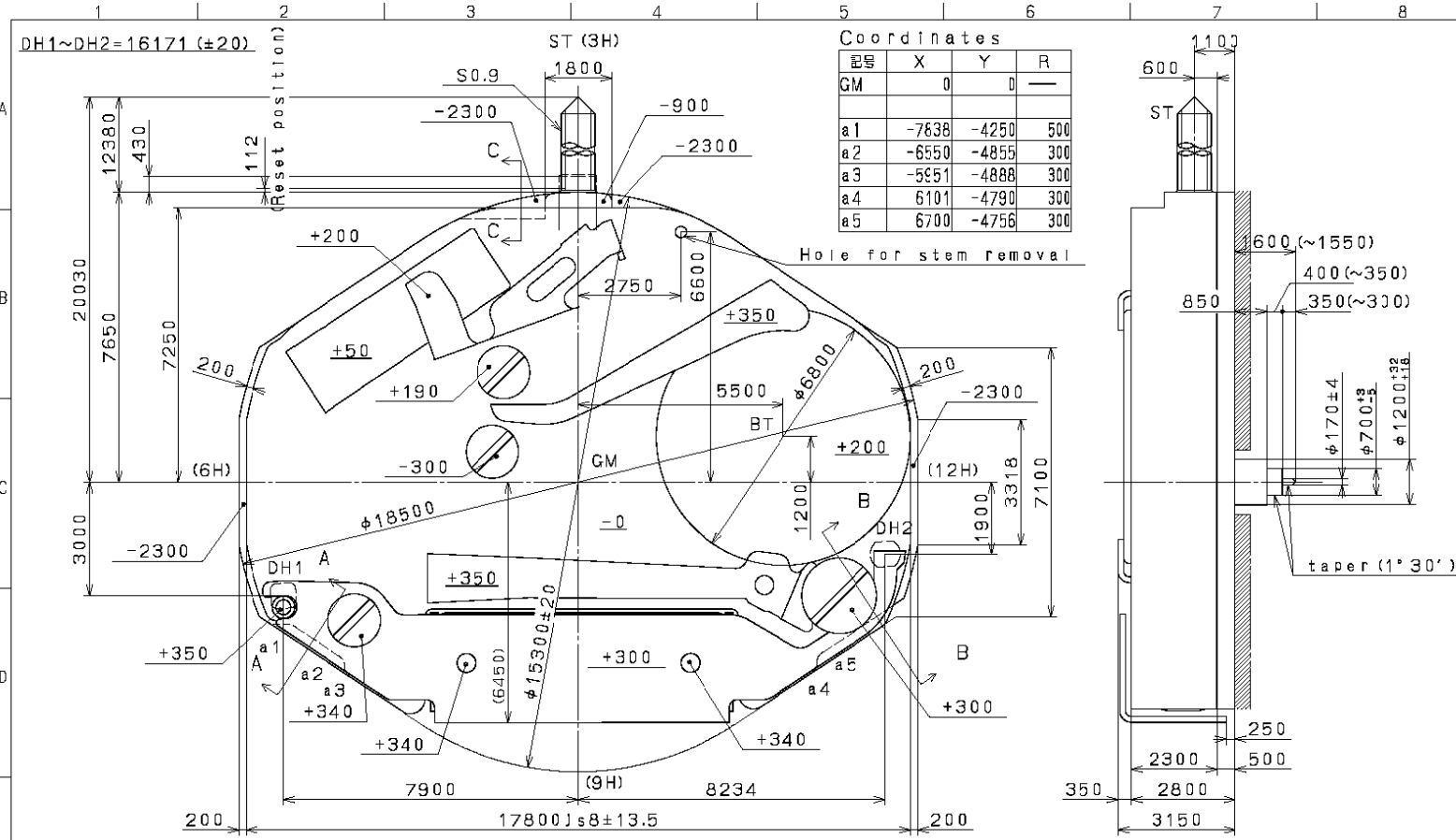

Quantity	Unit	Scale	Cal. NO. : 2035
	1 / 1000 mm	1 / 1	Parts No. :
Drawn	Date	Name	
Mark	Date	Description	Appr. Checked
Alterations	Approved	M. Fukuda	Name :
Material		General Tolerances	Frame for Case
Heat Treatment		Dimensions	Drawing No. : 2035C0AS
Hardness		Angles	
Plating			

MIYOTA

CITIZEN WATCH CO., LTD. TOKYO, JAPAN

2005/08/19 (10:22:51)

This drawing is provisional and subject to our reconfirmation and/or revision without notice.

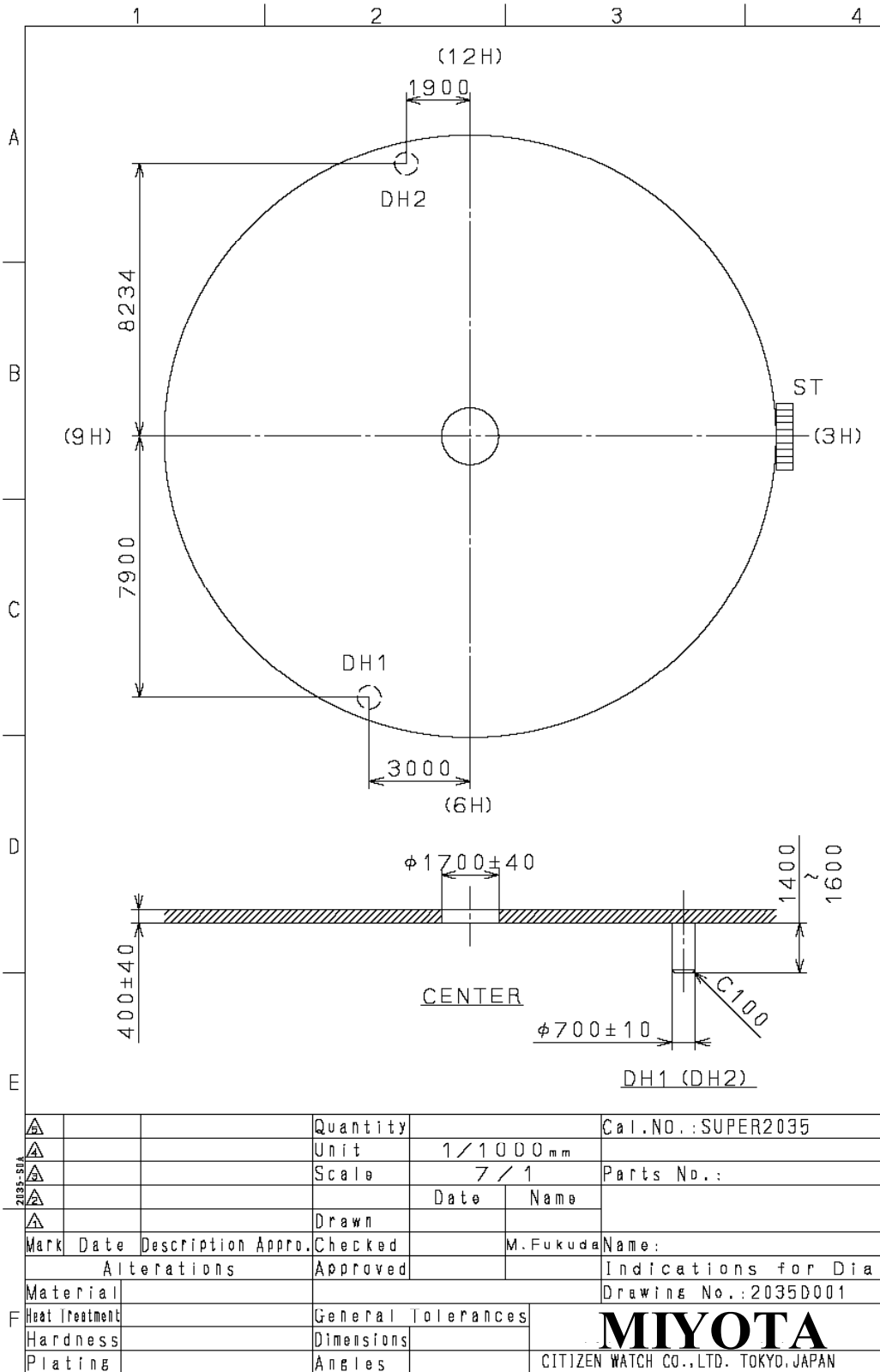

△				Quantity		Cal.NO.: SUPER2035
△				Unit	1/1000mm	
△				Scale	7/1	Parts No.:
△				Date	Name	
△				Drawn		
Mark	Date	Description	Appr.	Checked	M. Fukuda	Name:
Alterations				Approved		Indications for Dial
Material						Drawing No.: 2035D001
Heat treatment						MIYOTA
Hardness						
Plating						
						CITIZEN WATCH CO., LTD. TOKYO, JAPAN

This drawing is provisional and subject to our reconfirmation and/or revision without notice

065-468 (01) *** (2100-1121) 00-01-28

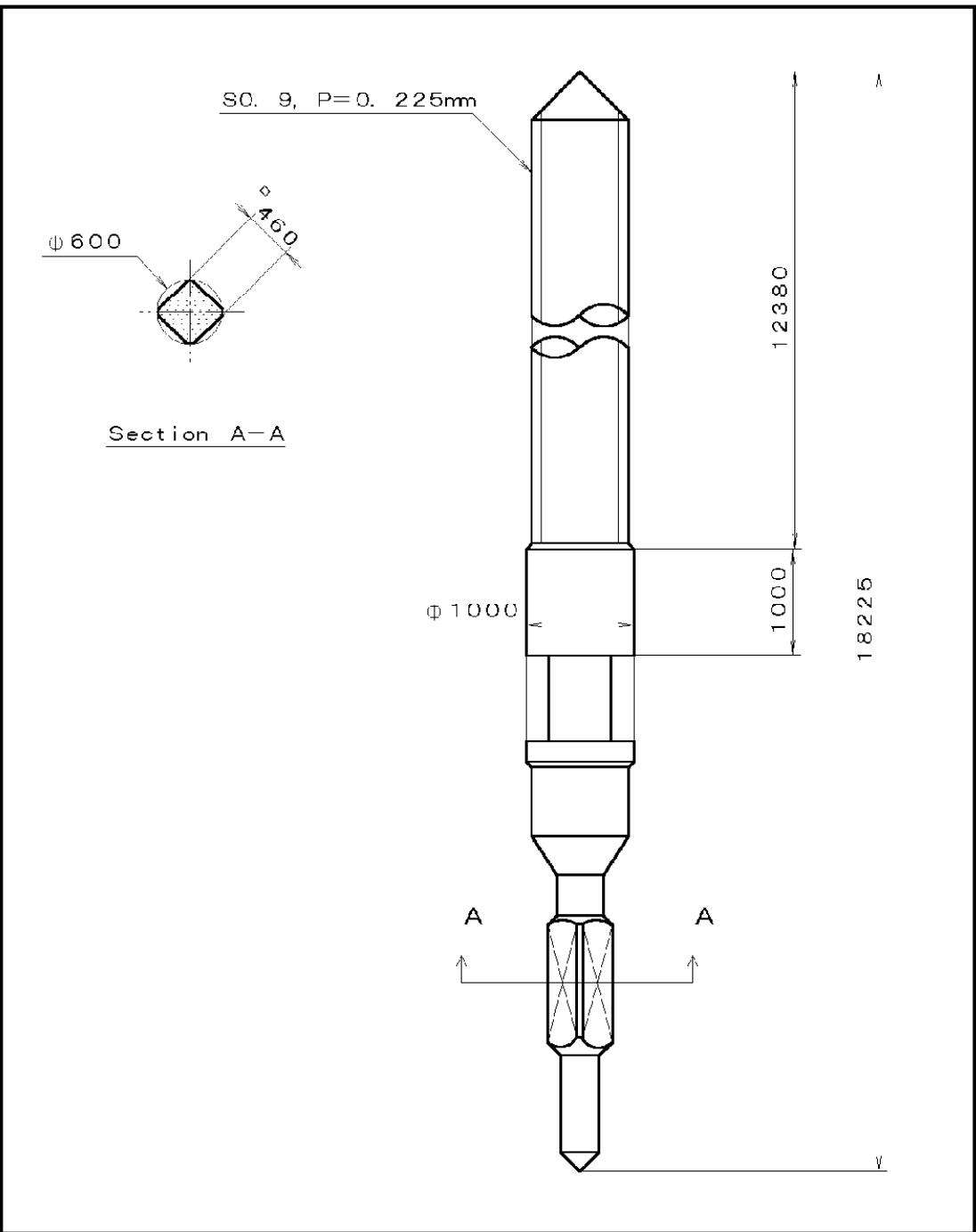

△			Quantity		Cal. No. :
△			Unit	1/1000 mm	
△			Scale	20:1	Parts:
△			Date		065-468
△			Drawn		Name:
△			Checked	T. Hiruta	SETTING STEM
△			Approved		Drawing No. : 4680S000
Material			General Tolerances		MIYOTA
Heat Treatment			Dimensions		
Hardness			Angles		
Plating					